

Auto Swing Auto Open Heat Press Manual

Model NO.: BEX 20/24

CONTENTS

I. Assembly Drawing	-----2
II. Technical Parameters	-----2
III. Operation Process	-----3-4
IV. Maintenance	-----5
V. Trouble Shooting For Transfer Print Quality	-----5
VI. Circuit Diagram	-----6
VII. Explosion View	-----7

I. Assembly Drawing



- | | | | |
|-------------------------|---------------------------|------------------------|----------------------|
| ○,1Digital Controller | ○,2Swing Shaft | ○,3Handle Shaft | ○,4Power Switch |
| ○,5 Connection
Plate | ○,6Heat Platen | ○,7Machine Base | ○,8Supporting Pillar |
| ○,9Swing Handle | ○,10Emergency Stop Button | ○,11 Braking
Handle | |

II. Technical Parameters

1. Model No.: BEX-20/24
2. Machine Dimension: 870*490*700mm
3. Heat Platen Size: 16"x20", 20"x24" (40x50cm, 40x60cm)
4. Printable Articles Max Size: 500*400*40mm
5. Voltage: 220V/1Phase; 110V/1Phase
6. Power: 220V/1.8KW; 110V/1.2KW
7. Recommend Setting: 30~280s; 180~200°C
Time Range: 0~999s
Maximum Temp: 225 C°
8. Packing Size: 94*64*89cm
9. Gross Weight: 82.5kg

III. Operating Process

1. Set temperature required

		
<p>Turn on power switch, temperature light is ON. The digital display shows</p>	<p>Press button, the light is on (C denotes Celsius). Press arrows “△” or “▽” to select “°C” or “°F” (F denotes Fahrenheit) according to your habits.</p>	<p>Press button, the temp light is on. Select with arrows the temperature according to different transfer material (Normally 180°C~200°C)</p>

2. Set time required

		
<p>Press button after temperature setting and the time light is on. Select with arrows the time according to different transfer material.</p>	<p>Press button after time setting; the display shows the temperature starts to rise. “CD-L” shows the time counting down during your transfer.</p>	<p>Note: There are two small port in front side of the digital display. If the real temperature is lower than digital controller shown, you can adjust the “hot port”; Clockwise to raise temperature; anticlockwise to reduce temperature.</p>

3. Printing methods

- Step 1: Make sure the cord is connected well to the wall socket. Place the object (i.e. T-shirt) on press bed, and transfer paper with images facing down the object, adjust pressure to your requirement.
- Step 2: Hold the swing handle (the handle on the front part of the heat platen), make the upper heat platen matches the under plate exactly. Pull the braking handle at the same time to fix the machine body not to swing. Then switch on the machine.
- Step 3: After setting the time and temperature, use the right hand to hold the swing handle, another hand to release the braking handle, then off the right hand from swing handle, you will find that the upper machine body will swing away to another side automatically. Then put the transfer paper and object on the silicon pad.
- Step 4: When the temperature rises to the set value, pull back the upper machine body, then press down the shaft

to make the upper magnet suck to the the under magnet sucker, then temperature starts to rise.

Step 5: Then the time counter is on, once time is up, the upper heat platen will auto open and swing away to another side automatically.

Step 6: Work finished and take out the object carefully.

P.S: consult the Transfer Paper instructions on whether to peel cold or hot, Here are suggested Pressing time guidelines for different transfer paper.

Ink-Jet Transfer Paper (fabric) 14-18 seconds

Laser Copier/Printer Transfer Paper (fabric) 18-25 seconds

Sublimation Transfers (onto Fabrics) 25-30 seconds

Sublimation Transfers (onto FR-Plastic/Woods) 60-70 seconds

5. Recommendations:

1) Ceramic tile transfer:

Set temperature: 180°C.

Set time: 15 seconds

2) T-shirt transfer:

Set temperature: 180°C.

Set time: (chemical fiber use for sublimation transfer paper: 30-50seconds; pure cotton use for T-shirt transfer paper: 10-20seconds)

NOTE:

1) Please switch off the machine and unplug the power cord when the machine is not in use.

2) The heat platen will cool down to the room temperature, if heat press stays un-use for more than 30 minutes.

3) The heat-releasing fan will automatically starts when the temperature of heat platen reaches 80 degree C (176 degree F). It helps to reduce the temperature of electrical parts and prolong the service life of them.

4) For better maintenance of heat press, the maximum setting temperature is 210 degrees C (410 degrees F).

5) To avoid re-heating the first transfer when printing double sided T-Shirts, insert a sheet of cardboard in between the shirt, adjust the height to less pressure, then press.

6) Heat platen may pivot slightly back and forth rotationally. This is due to movement allowance within the clamp assembly, and is normal.

IV. Maintenance

1. No action after turn on the machine

- 1). Check the plug whether it connects well or whether it is broken.
- 2). Check the power switch or digital controller whether it is broken.
- 3). Check the fuse whether it has been burnt out.
- 4). Indicating light is on, but no display on screen, check the 5 cable of Railway transformer. If it's loosening, showing the problem is poor connection. If they connects well, showing that the Transformer is faulty.

2. The display screen are working well, but no temperature increasing on the heat platen.

- 1). Check whether the thermocouple of the heat platen touches well. If the thermocouple is loose, the display will show 255 and machine keeps beeping.
- 2). Check if the indicating light of solid-state relay is on, if not, check if the relay or digital controller is broken.
- 3). If you already changed the new solid-state relay but the heat platen still can't heating up, check if the heat platen is faulty or the heat platen's power cable is loose, need to change by new heat platen.

3. The heat platen works well, but suddenly the display screen show 255°C.

- 1). Check whether the thermocouple of the heat platen touches well.
- 2). If the thermocouple touches well but still show 255°C, then it is faulty.

4. The machine is heating during 0~180°C, but display number jumps to above 200°C or 300°C suddenly, or the numbers on display jumps irregularly.

- 1). Check whether the thermocouple of the heat platen touches well.
- 2). If the thermocouple is good, It shows that the program of digital controller is broken, which namely IC or is broken, need to change by new controller.

5. The temperature is out of control: Set 180°C but the actual temperature is above 200°C

- 1). It means the solid-state relay is broken, out of control, need to change the relay.
- 2). Or the digital controller is faulty and it keeps conveying electric to relay, need to change controller.

6. The setting temp and time becomes abnormal after exchange the heat platen

- 1). Please reset the temp and time according the operation process manual.

7. Other notice

- 1). In order to prolong the machine service life, please add the lubrication oil regularly on the joints.
- 2). In order to keep the heat platen's good transfer effect, you need to protect the heat platen carefully whenever you are using it or not.
- 3). Please keep the machine in dry place.
- 4). If you are not able to solve the electrical parts problem, please kindly contact the supplier and get technical support.

V. Trouble shooting for transfer print quality

1. If the print color is pale: the temperature is too low / the pressure is not correct / or not pressed long enough.
2. If the print color is too brown or the transfer paper is almost burnt: reduce the setting temperature
2. If the print is blurring: too much transfer time causes proliferation.
3. If print color is different/ partial transfer effect is not good enough: the pressure is not enough / or not pressed long enough / or poor quality transfer paper.
4. If transfer paper stick to the object after transfer: the temperature is too high/ or poor quality printing ink.

VI. Circuit Diagram

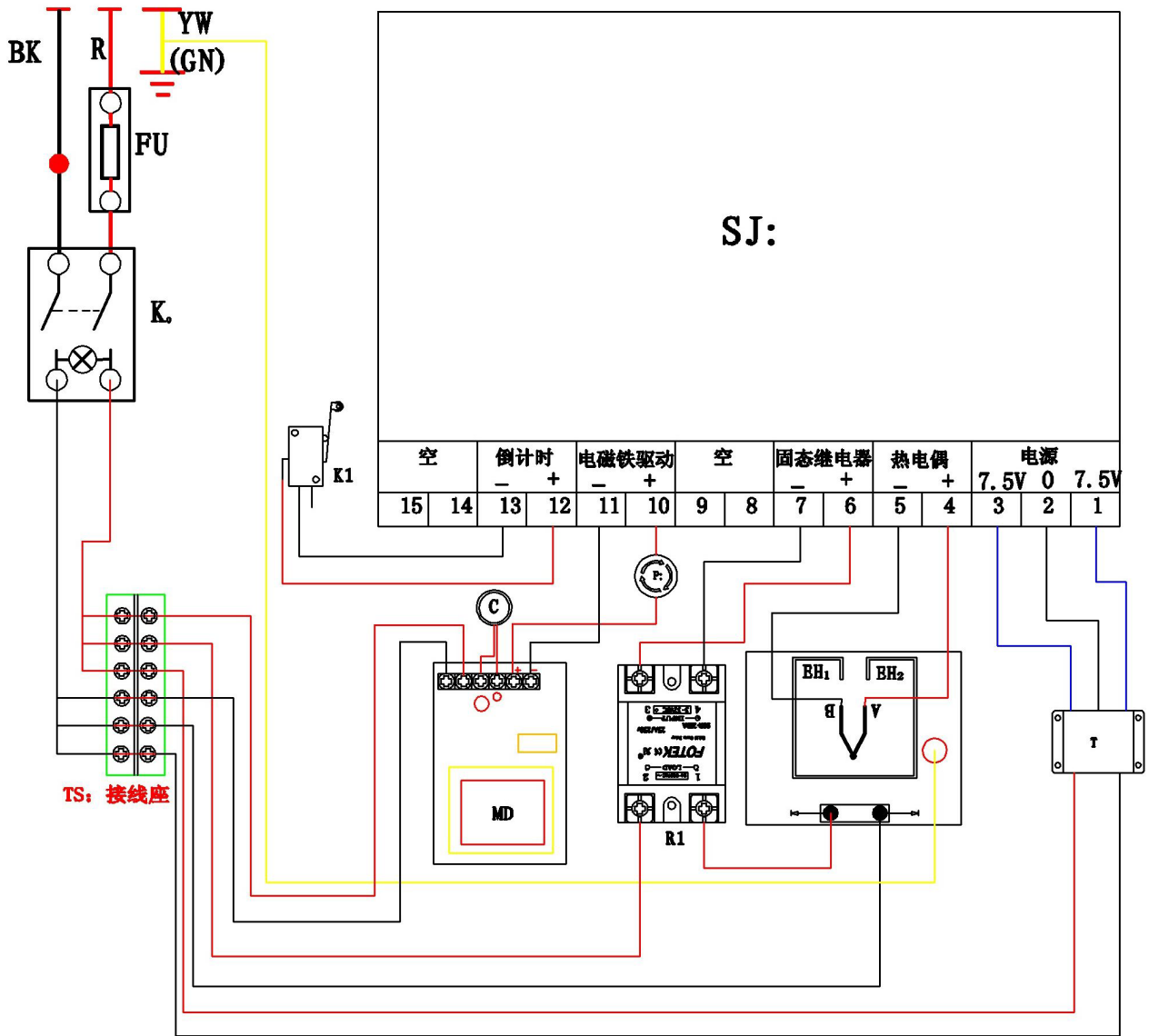

K₀: Power Switch

SJ: Digital Controller

C: Magnet

K₁: Limit Switch

MD: Magnet Driver

FU: Fuse (15A/25V)

P₁(P₂): Emergency Stop Button

EH₁EH₂: Heating Pipe

R₁: Relay

VII. Explosion View

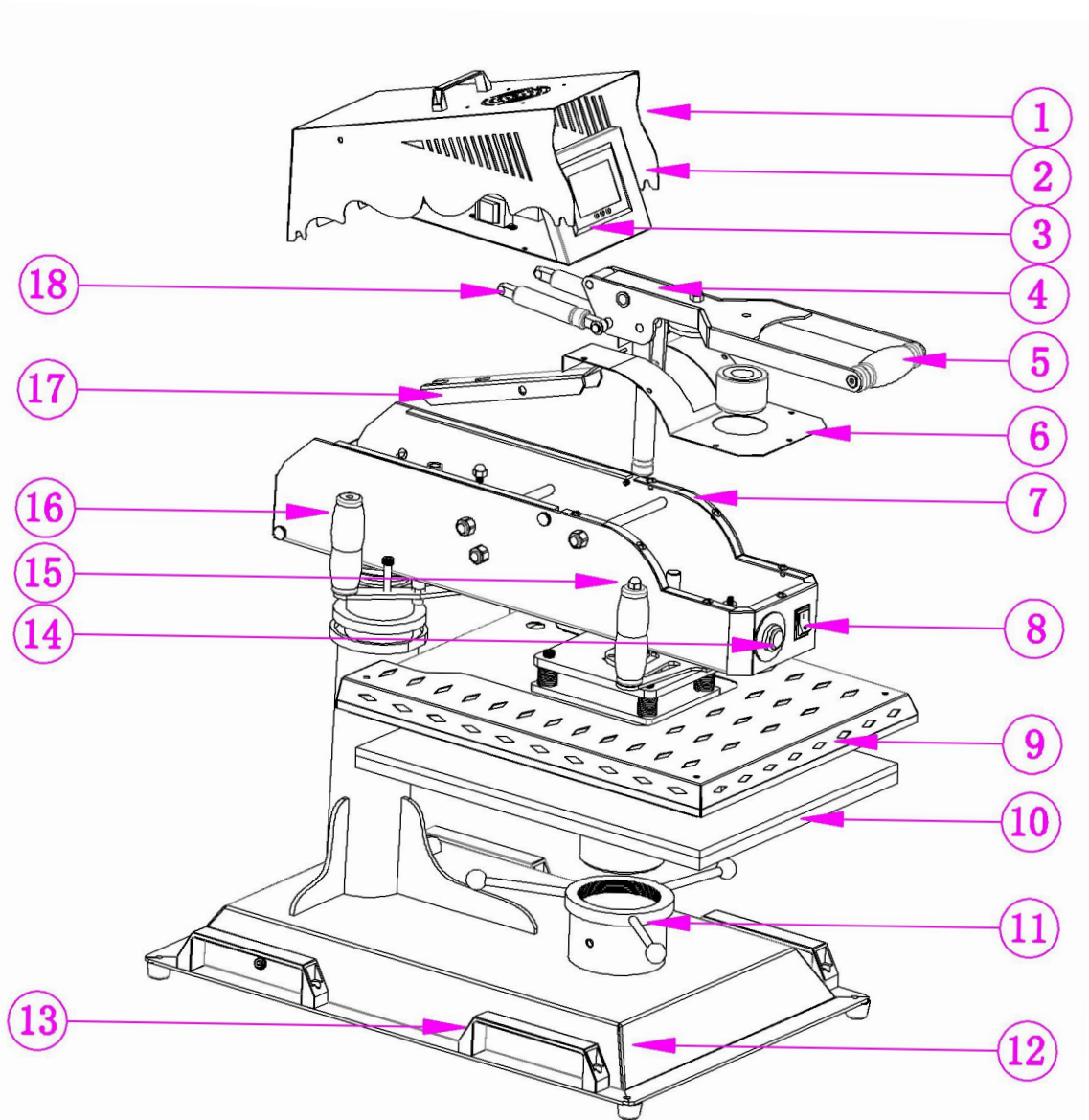

No.	Parts Name	Qty
1	Electrical Case Cover	1
2	Electrical Components	1
3	Digital Controller	1
4	Handle Shaft	1
5	Handle Bar Grip	1
6	Front Cover Case	1
7	Swing Shaft	1
8	Power Switch	1
9	Heat Platen	1

10	Under Plate	1
11	Pressure Adjusting Knob	1
12	Machine Base	1
13	Lift Handle	1
14	Emergency Stop Button	1
15	Swing Handle	1
16	Braking Handle	1
17	Clutch Lever	1
18	Gas Spring	1