

MODEL-A15 / MODEL-A20

Operation Manual

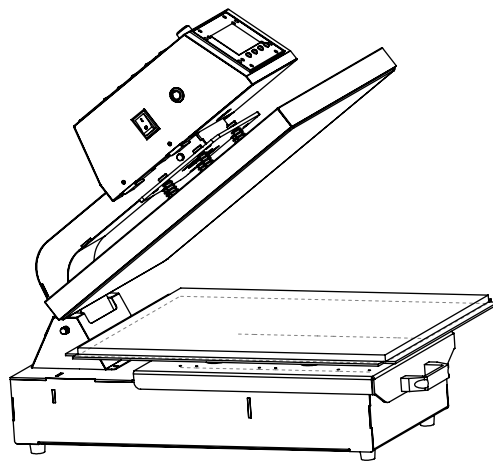

CONTENTS

I. Technical Parameters -----	2
II. Assembly Drawing -----	3
III Operating Instructions -----	4-5
IV.Maintenance-----	6
V. Trouble Shooting -----	7
VI. Exploded View -----	8
VII.Circuit Diagram -----	9

I. Technical Parameters

Model No. : MODEL-A15 / MODEL-A20

Description: Auto Open, Slide-out Under Plate

Heat platen sizes: 380x380mm (15"x15") / 400x500mm (16"x20")

Controller: GY-08 Controller, dual time setting

Voltage: 120V/220V single-phase

Current: 14A/8.2A

Frequency: 50Hz/60Hz

Power: 1.6KW/ 1.8KW

Temperature range: 0-230°C

Temperature Accuracy: $\pm 5^{\circ}\text{C}$

Time range: 0-999S

Machine Size: 635x406x402mm (40x50cm)

Net Weight: 43KG (40x50cm)

Gross Weight: 49.5KG (40x50cm)

Packing Size: 780x540x550mm (40x50cm)

Main Features:

1. Fully electric control: no need noisy air compressor.
2. Auto press down & auto open with safe start button.
3. GY-08 controller with dual time setting can store frequently used settings, production cycle counter. Perfect for high volume commercial

use, specialty decorators, direct-to-garment printing, and embossing etc.

II. Assembly Drawing

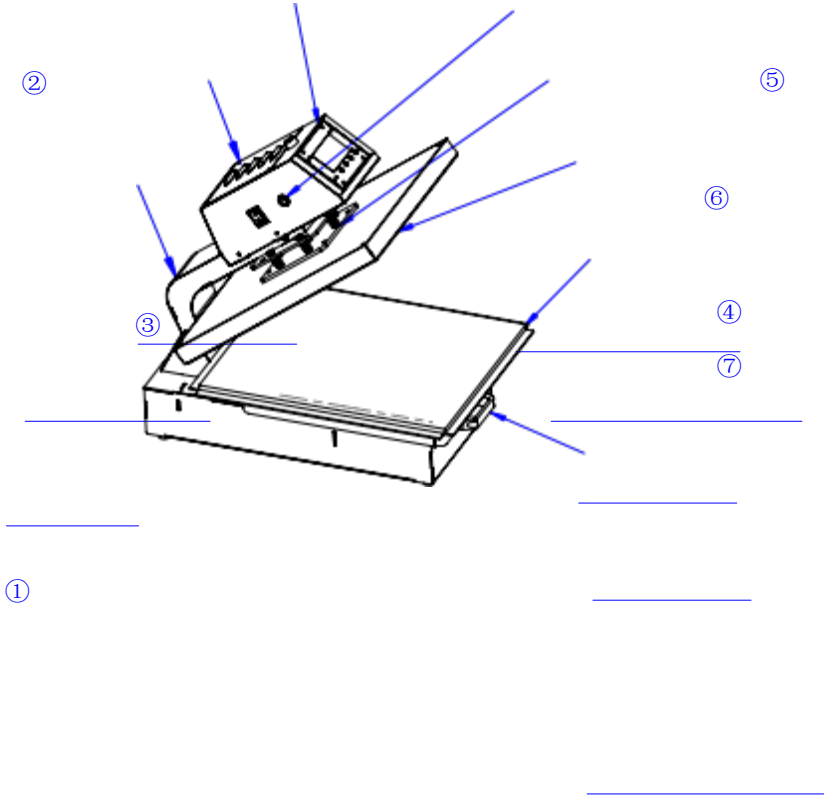

- ① Machine Assembly
- ② Control Panel Assembly
- ③ GY-08 Digital Controller
- ④ Dual Start Button
- ⑤ Force Spring Distribution Assembly
- ⑥ Heat Platen Assembly

⑦Heat Press Pad

⑧Heavy-duty Slide-out Lower Platen

III. Operating Instructions

1. Plug the power cord into a standard 120V or 220V outlet and turn on the heat press by pressing the power switch located on the side of machine.

Be sure that your heat press is positioned evenly on a steady and level surface. If using an extension cord, be sure it is industrial grade.

2. Heat transfer parameters settings.

A. Press "OK" button to enter TEMPERATURE setting

When the TEMP indicator blinks, use Up/Down buttons " " " " to set the required temperature and then press "OK " button again to complete the temperature setting.

B. Press "OK" button to enter PREHEAT TIME setting

When the TIME1 indicator blinks, use Up/Down buttons "" "" to set the required time for preheating and then press "OK" button again to complete the setting.

C. Press "OK" button to enter TRANSFER TIME setting

When the TIME2 indicator blinks, use Up/Down buttons "" "" to set the required time for transferring and then press "OK" button again to complete the setting. If you don't need to preheat the transfer material, TIME1 and TIME2 can be set in same values, and then the machine will be operating in same transfer parameters in cycle.

D. After finishing above-mentioned settings, your machine is ready for pressing.

3. When the temperature reached to the set value, you can start the transfer printing by following below steps:

A. Pull out the under plate, and place the transfer material flat onto the heat press pad

B. Push the under plate back to its original position.

C. Press the start buttons with BOTH hands at the same time, heat platen press down automatically, TIME1 indicator blinks and preheat timer starting to countdown.

D. When the timer counts to 3, the buzzer sounded; the heat platen opens automatically when the time counts to end.

E. Pull out the under plate, lay the transfer paper over the transfer material, then push the under plate back to its original position.

F. Press the starting buttons with BOTH hands at the same time, heat platen press down automatically, TIME2 indicator blinks and the transfer timer starts to countdown.

G. When the timer counts to 3, the buzzer sounded; heat platen opens automatically when the time counts to end.

H. Pull out the under plate, and take out the transferred material. The pressing is finished.

Note: If you don't need to preheat the transfer material, set the TIME1 and TIME2 in same value, then the machine will be operated in transfer parameters in cycle.

4. During the operation, if there is an unexpected situation for an emergency stop, press the "Reset" button to stop this operation.

5. During operation, the operator should pay attention to safety protection, avoid body touching on hot spots from crush injuries and burn risks.

6. This machine helps to minimize the physical labor of operator; it has self- intermittent function to make it possible to work long hours. One operator can do multi-machine pressing at same time to increase the efficiency of work.

IV. Maintenance

1. It's necessary to maintain the machine regularly for stabilizing its performance, prolong service life, and to ensure the transfer process goes smoothly.
2. Fill or smear the lubricants on main active friction parts regularly.
3. Check the main parts frequently to make sure the screws are well fastened all the time.
4. Please set suitable transfer parameters (opening angle/temperature/time) according to the transfer materials. It could cause the machine overloaded and damage heat platen by setting excess values.
5. Please follow above mentioned operating instructions correctly to prevent accidents from happening during the operation.

V. Trouble Shooting

1. Pusher lift with active gap.

Analyze: locking nut loose on Push rod bearing (refer to below picture)

Solutions:

a. Loosen the hand wheel screws on both sides of the davit arm cover, and open the cover.

b. Remove the motor set screws, pull the motor out .

c. Insert the Needle-nose pliers into the Lock nut screwed hole to tighten the lock nut according to the ft you required, then tighten the compression screw.

d. Install the motor back, and tighten the Motor set screw, then close the davit arm cover.

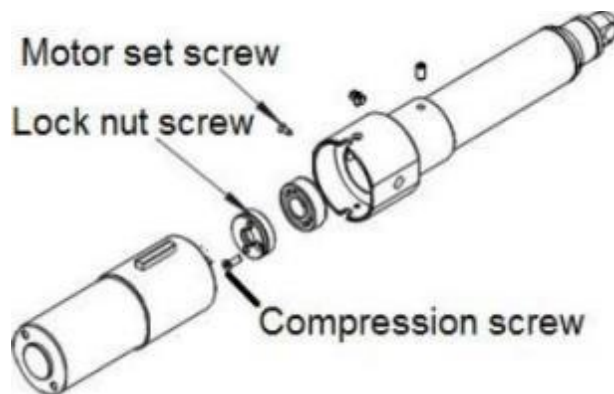

2. Large area of transferred paper with residual colors remains after heat transfer.

Analyze: The setting temperature is too low.

Solution: Increase the temperature properly.

3. Transferred paper appear brown color after heat transfer

Analyze: The temperature setting is too high

Solution: Decrease the temperature properly.

4. Part of the transferred image with bad transfer result.

Analyze: The pressure on the heat platen is not even.

Solution: Adjust the mold spring pressure on heat platen cover. Try to loosen the spring that near bad transferred area, or tighten the springs on other areas.

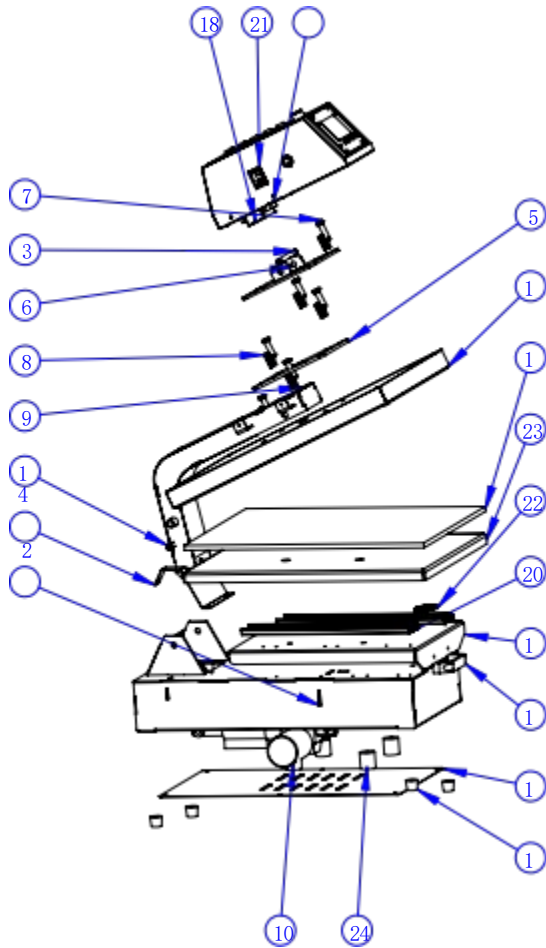

Item NO.	Part NO.	Material	Qty
1	Frame assembly	A3	1
2	Sealing plate for machine frame	A3	1
3	Bolt	Round steel	2
4	Spacer sleeve	POM	2
5	Heating plate adapter	A3	1
6	Adapter plate assembly	A3	1
7	M6X35 slotted axial screw	45#	6
8	Spring	A3 board	6
9	Lifting arm assembly	A3	1
10	L series electric push driver S70-V15	/	1
11	Slide-out lower platen	A3	1
12	Handle	Nylon	1
13	Machine feet	A3 board	4
14	Chrome-plated rod	Round steel	1
15	Sealing plate for machine base	A3	1
16	380/45 Heating plate	/	1

17	38x38 / 40X50cm pad	A3 board	1
18	Transformer	/	1
19	Solid state relay	/	1
20	Sliding rail assembly 350	45#	2
21	A series electric box assembly 380	/	1
22	380B limit switch	/	1
23	380/45 sheet metal lower platen	A3 board	1
24	Supporting block for lower platen	Aluminum rod	4

REVISION	MODIFIED ITEM	ORIGINAL	CHANGE TO	REMARK	RELEASED BY	DATE
A						2023-5-18

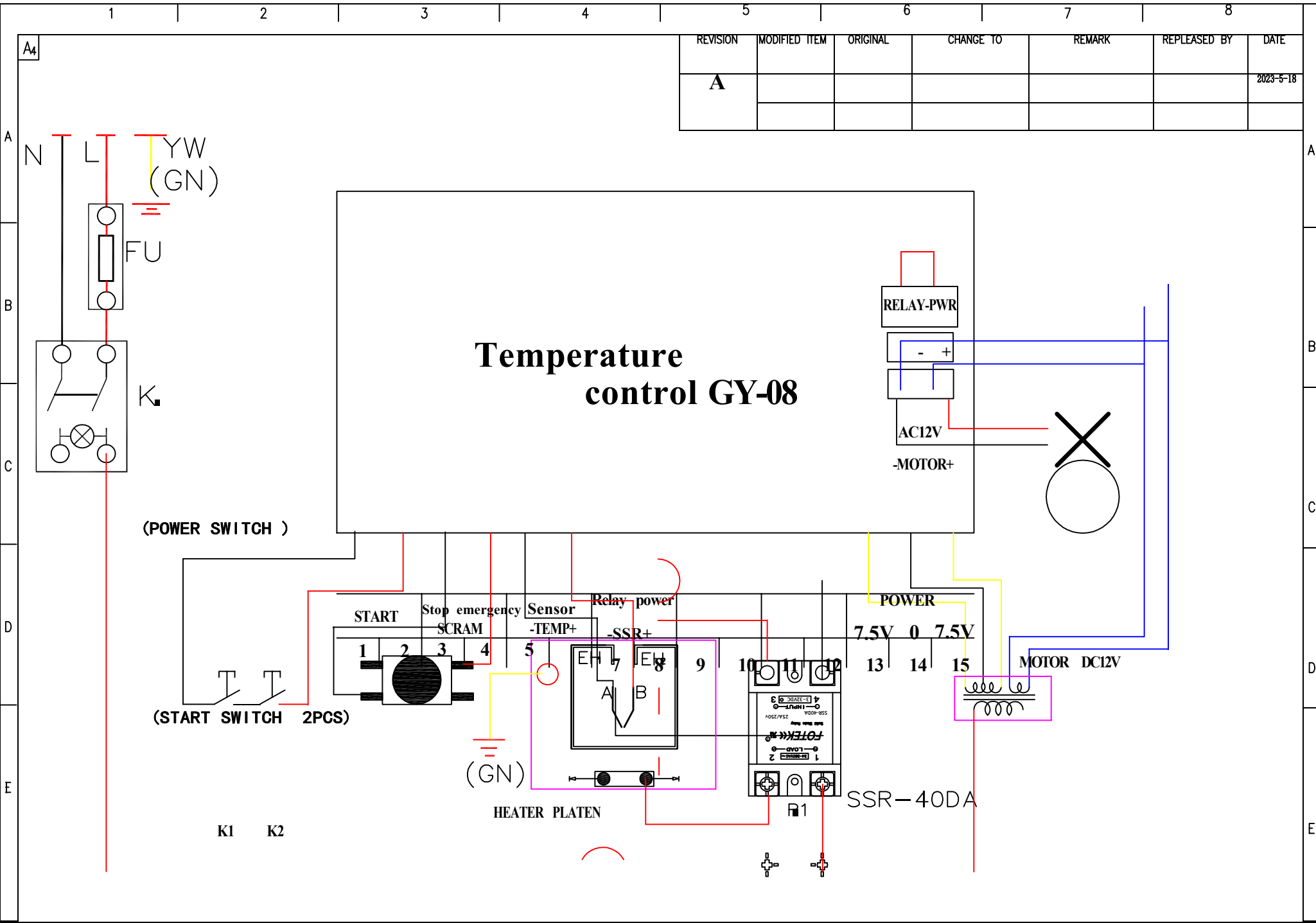

RESET

TRANSFORMER

Relay Solenoid

 东莞国扬打印耗材有限公司 MICROTEC PRINTER CONSUMABLE CO.,LTD	
产品编号: A15-20	类别名称: 电路图
产品名称: 推杆电动机	制 图: 刘延河 2023-05-18

1 2 3 4 5 6 7 8

